

Volans Aston 24v DC Code : GT.ASTON 1212

CE **IP 67** CRI>93 ³SDCM

Description

Sealed linear flexi LED. IP67 made to measure. UV and chemical resistant. Suitable for indoor / outdoor applications. UPTO 20m IN ONE RUN. IK08

Materials PCB in Polyurethane encapsulation

Colour finish clear

Dimensions (mm) 12x12mm without clips **Weight (KG)** 50g/m

Light Source

Option A. 10w LED (650 lms. nom.)	white	120°	2700K / 3000K / 4000K
Option B. 10w LED (750 lms. nom.)	tuneable	120°	tuneable 2700K-5500K
Option C. 10w LED (300 lms. nom.)	RGB	120°	RGB

Dimming Mains, 0-10v or DALI, Casambi  dimming control (remote)

Special Notes

36mm cutting intervals see p.3 for further details



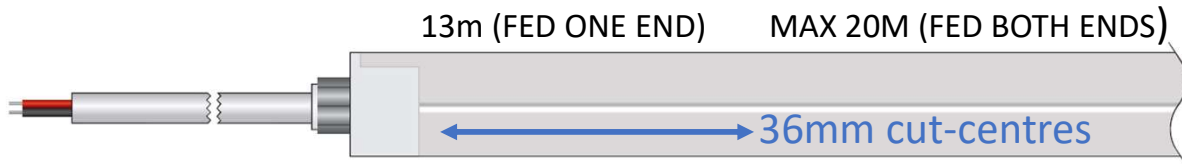
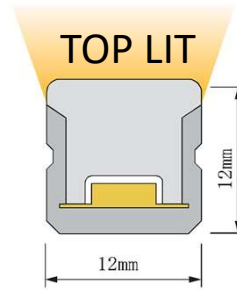
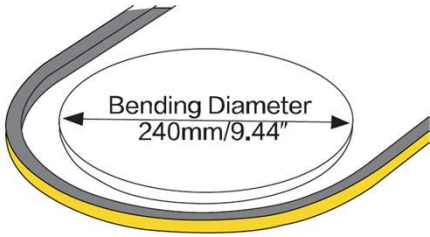

A assembled locally
(outer connections)



End feed



Side feed



Bottom feed

B factory sealed
(seamless connections)



End feed



Side feed



Bottom feed



Aluminium Profile
Order Code: AC017-AP
Dimension: 1000x17.2x14mm/
39.37"x0.68"x0.55"(LxWxH)
Material: aluminium
Color: silver



Mounting Clips
Order Code: AC018-SET
Dimension: 20x12.8x10.9mm/
0.79"x0.50"x0.43"(LxWxH)
Material: stainless steel
Color: silver
Each meter led strips needs
2 clips + 2 screws



HANDLING INSTRUCTIONS

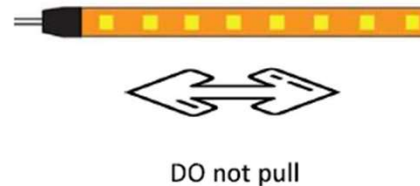
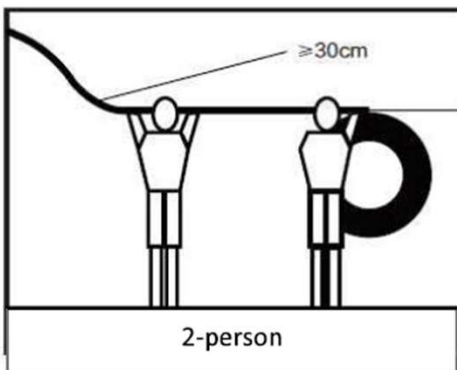

Do not allow the tape to sag or hang, as this can damage the electrical connections within it.

Please observe the following points when installing LED tape. The reliability of the LED is directly related to the standard of installation.

- 1) Ensure a suitable location is identified for the driver. It is advisable to use a driver with at least 25% more capacity (wattage) than the load it is driving. It is also advisable to locate the driver as close to the LED as reasonably possible.
- 2) LED tape is 'constant voltage' and as such is always wired in parallel.
- 3) For runs in excess of 5m in total, it is necessary to power the tape from both ends. (SEE BELOW DIAGRAM)
- 4) Keep all DC cables as short as practicably possible to avoid 'volt drop'.
- 5) **Do not hit or press the LED tape to avoid damage to the chips and current limiting resistors.**
- 6) Do not allow the tape to hang or sag, as strain can damage it. Tape should never be under stress or strain – never under tension.
- 7) Always mount the LED on a metallic surface to prevent overheating. Ensure the mounting surface is clean and free of grease, oil and contamination.
- 8) Never bend, crease or fold the LED tape – doing so can cause 'dark spots' between cut points.
- 9) If the LED is being mounted in a damp location, ensure IP rated connections are used – we recommend gel filled connectors.
- 10) If the driver has an earth wire or terminal, this must be used.

MAINS DIM STATIC COLOUR

If LED strip is greater than 5m then circuit must be wired as a ring. Drivers can be mounted up to 20m away, provided the above is respected and 1.5mm cable used from the driver to the LED strip. In cases of drivers mounted over 10m from strip a bench test is recommended.

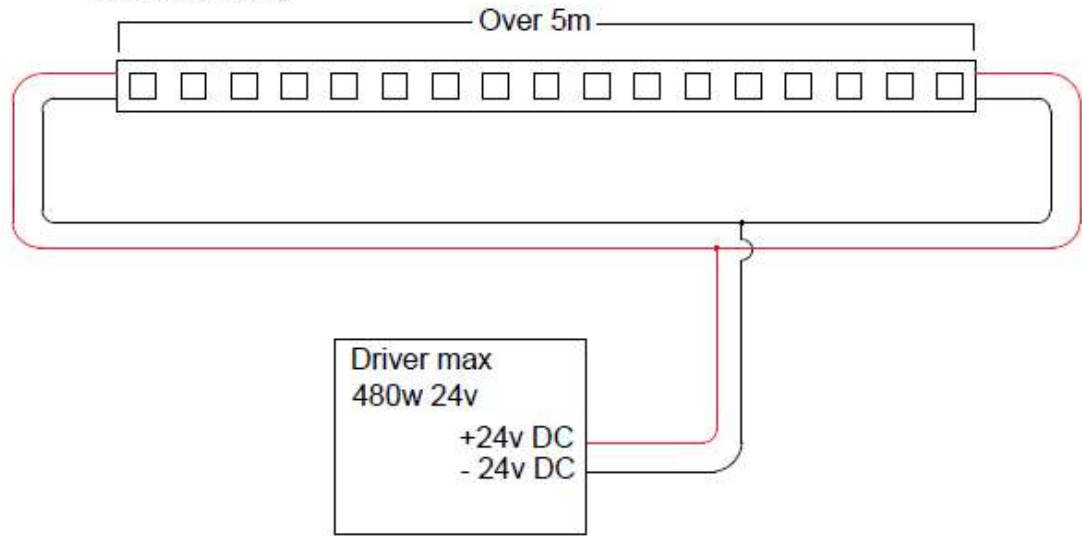

L.V / DALI DIM STATIC COLOUR

This circuit is the standard layout for LED strip of 5m or less. for 5.1m - 10m strip should be fed from both ends (separate diagram available)

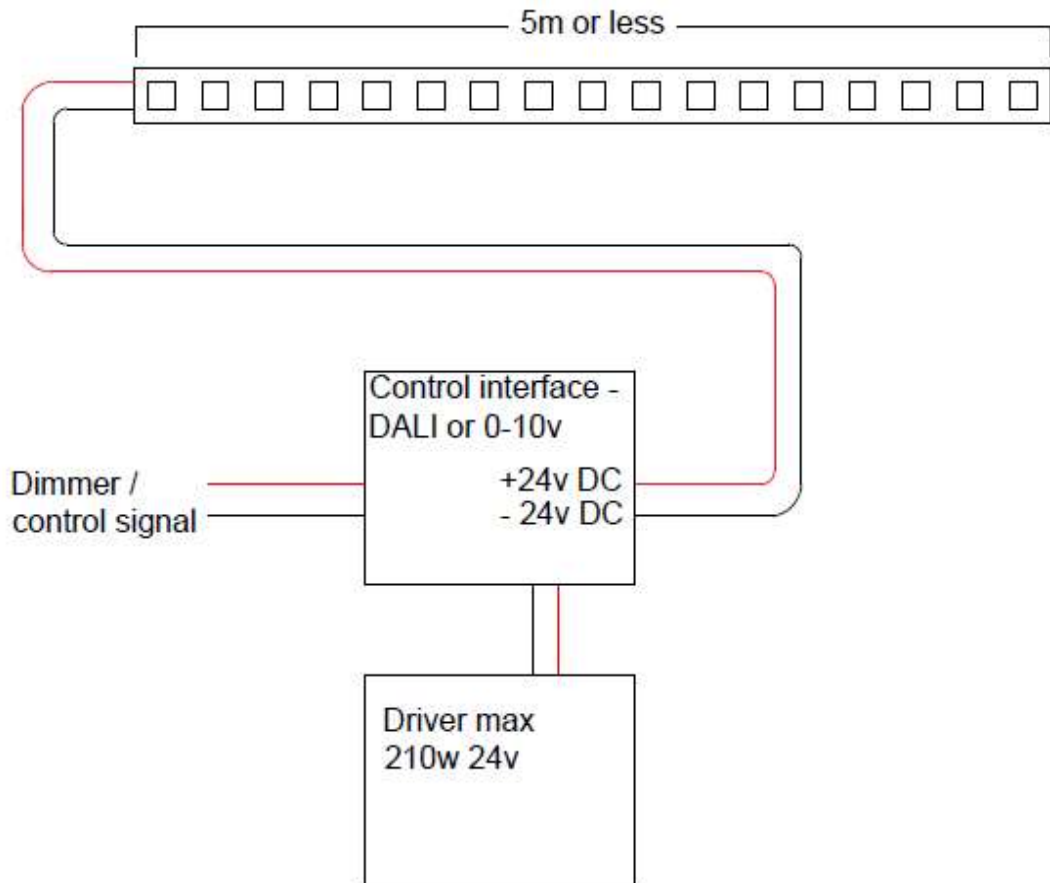

TUNEABLE DIM

This circuit is the standard layout for LED strip of 5m or less. for 5.1m - 10m strip should be fed from both ends (separate diagram available)

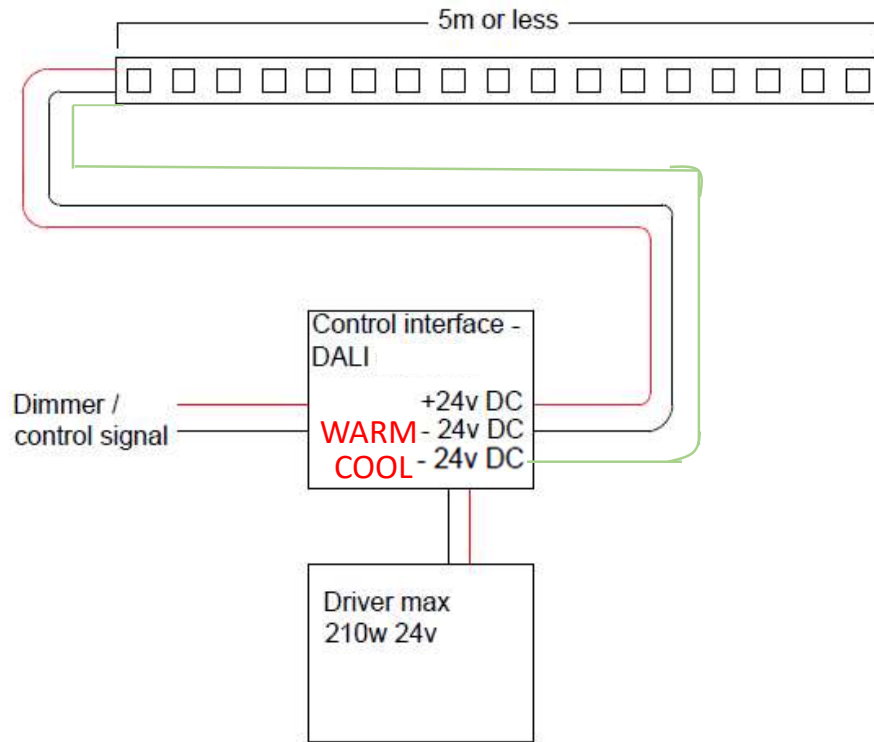

RGB DIM

If LED strip is greater than 5m then circuit must be wired as a ring. Drivers can be mounted up to 20m away, provided the above is respected and 1.5mm cable used from the driver to the LED strip. In cases of drivers mounted over 10m from strip a bench test is recommended.

